



EGG HATCHER

HATCHING CONTROL DEVICE

USER MANUAL

EMKO ELEKTRONİK A.Ş.
Demirtaş Org. San. Blog.
Karanfil Sk. No:6 TR
16369 Bursa / TURKEY

Telefon:0224 261 1990
Faks: 0224 261 1912
Web Sitesi: www.emkoelektronik.com.tr
email: exposales@emkoelektronik.com.tr

User Manual ENG EGG HATCHER 02 V01 04/16

CONTENT

1	INTRODUCTION	3
1.1	General Specifications	3
1.2	Warranty	4
1.3	Maintenance	4
1.4	Ordering Information	5
2	INSTALLATION	5
2.1	General Description	6
2.2	Front View, Dimension and Panel Cutout Off EGG-HATCHER	6
2.3	Mounting	8
2.4	Electrical Wiring Diagram	9
3	MAIN OPERATION SCREEN AND GENERAL DESCRPTION	11
3.1	Main Operation Screen	11
3.2	Second Working Page	12
3.3	Menus	13
3.4	Button Definetions	14
4	SHUTTER CONTROL	15
5	SETTINGS	16
6	ADVANCED SETTINGS	17
6.1	Control Parametres	18
6.1.1	General Parameters	
6.1.2	Temperature Parameters	
6.1.3	Humidity Parameters	
6.1.4	Temperature Alarm Parameters	
6.1.5	Humidity Alarm Parameters	
6.1.6	Water Spray Parameters	
6.1.7	Shutter Parameters	
6.1.8	Tray Rotation Parameters	
6.1.9	Hatching Parameters	
6.2	Device Settings	28
6.2.1	Date & Time Settings	
6.2.2	Update Software	
6.2.3	Default Settings	
6.2.4	Change Password	
7	LOGS	31
8	ALARMS	32
9	LANGUAGE SELECTION	33
10	ALARM TYPES	34

11	SPECIFICATIONS.....	35
12	OTHER INFORMATIONS.....	36

1. INTRODUCTION

1.1. General Specifications

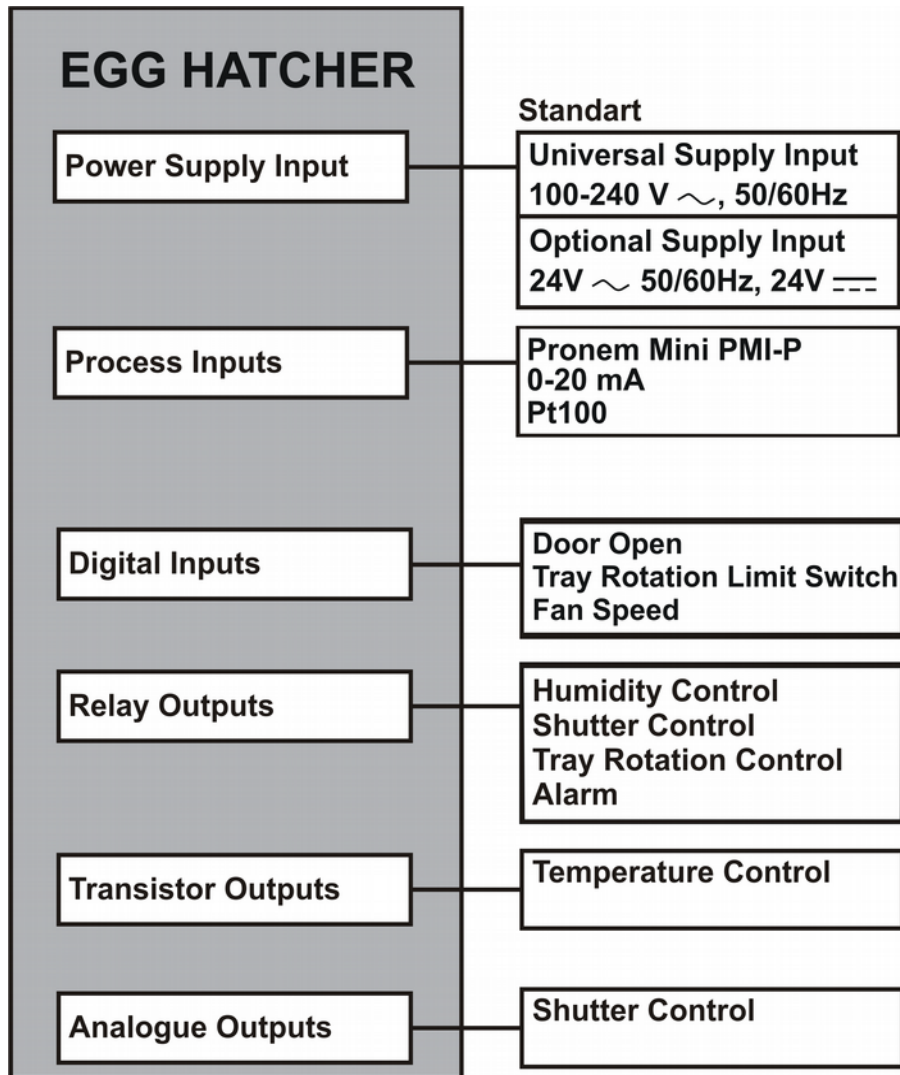

1.2. Warranty

EMKO Elektronik warrants that the equipment delivered is free from defects in material and workmanship. This warranty is provided for a period of two years. The warranty period starts from the delivery date. This warranty is in force if duty and responsibilities which are determined in warranty document and instruction manual performs by the customer completely.

Emko Elektronik, warns the user that the device has complex structure and may not be completely free of errors. It's the responsibility of the user to make provision by installing an independent alarm system besides EGG HATCHER, against possible errors that can result from manufacturing or design errors or non-standard environmental conditions (electrical noise, lightning, humidity, temperature, etc), although EGG HATCHER device is designed, manufactured and tested according to related standards. Emko Elektronik is not responsible for losses that occurs with possible errors.

It's strongly recommended to install an independent alarm system that warns the user and provide at least minimum conditions for animals to live.

Also, Emko Elektronik isn't responsible for results from misuseage of the device.

Warranty is limited for only changing or repairing defected device.

1.3. Maintenance

Repairs should only be performed by trained and specialized personnel. Cut power of the device before accessing internal parts.

Do not clean the case with hydrocarbon-based solvents (Petrol, Trichlorethylene etc.). Use of these kind of solvents can reduce the mechanical reliability of the device. Use a cloth dampened in ethyl alcohol or water to clean the external plastic case.

1.4. Ordering Information

EGG HATCHER (96 x 96 1/4 DIN)		A	/	BC	D	EFG	H
			/				
A	Supply Voltage						
1	100...240V ~ (- %15;+%10) 50/60Hz						
2	24V ~ (-%15;+%10) 50/60Hz 24V= (-%15;+%10)						
BC	Cabin Temperature & Humidity Inputs						
66	Pronem Mini PMI-P + PT100						
20	2 x 0...20mA + Pt100						
D	Output Type						
1	8 x Röle + 2 x SSR + 1 x Analog (0...20mA)						
EFG	Optional Communication						
000	Yok						
200	RS-232						
20U	RS-232 + USB						
240	RS-232 + RS-485(500 VAC Isolation)						
2E0	RS-232 + ETHERNET						
2EU	RS-232 + ETHERNET + USB						
24U	RS-232 + USB						
H	Sensör						
0	There is no sensor in the device box.						
6	PMI-P Pronem-Mini Digital Humidity and Temperature Sensor						

2. INSTALLATION

Before commencing installation:

- Disconnect all electrical power to the machine.
- Make sure the machine cannot operate during installation.
- Follow all of the machine manufacturer's safety warnings.
- Read and follow all installation instructions.

A visual inspection of this product for possible damage occurred during shipment is recommended before installation. It is your responsibility to ensure that qualified mechanical and electrical technicians install this product.

Be sure to use the rated power supply voltage to protect the unit against damage and to prevent failure.

Keep the power off until all of the wiring is completed so that electric shock and trouble with the unit can be prevented.

Never attempt to disassemble, modify or repair this unit. Tampering with the unit may result in malfunction, electric shock or fire.

Do not use the unit in combustible or explosive gaseous atmospheres.

During the equipment is putted in hole on the metal panel while mechanical installation some metal burrs can cause injury on hands, you must be careful.

Montage of the product on a system must be done with it's own fixing screws. Do not do the montage of the device with inappropriate fixing screws. Be sure that device will not fall while doing the montage.

It is your responsibility if this equipment is used in a manner not specified in this instruction manual.

Report any shortage or damage to your local sales office as soon as possible.

2.1 General Description

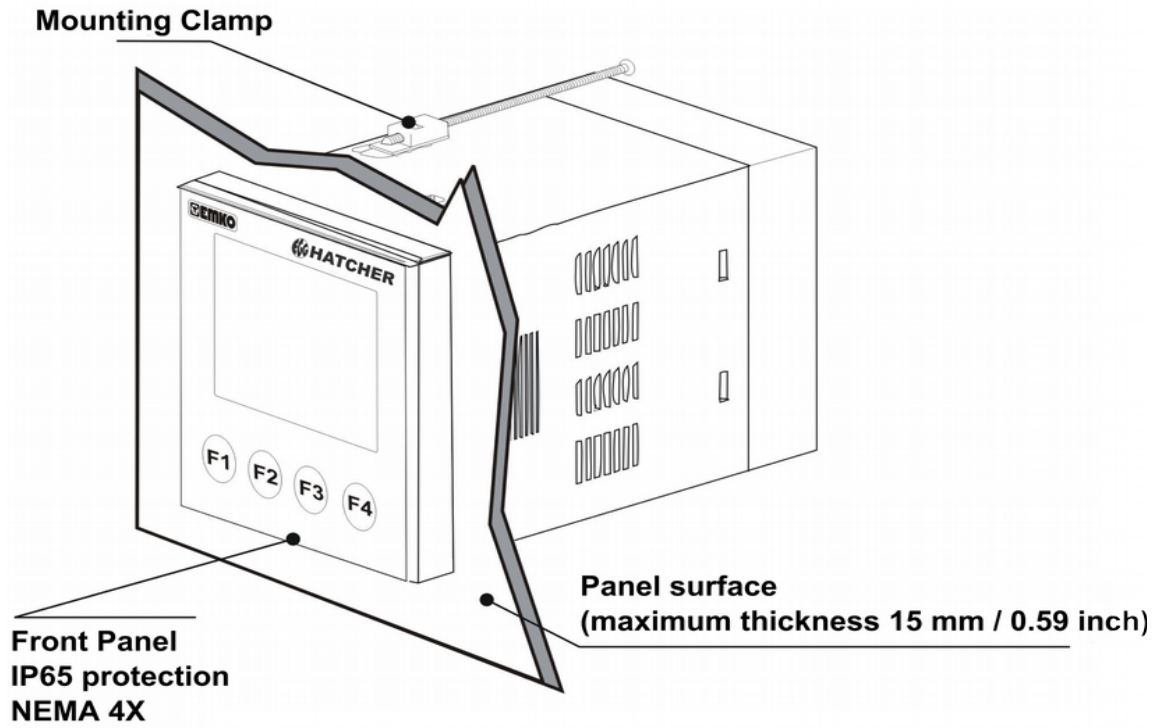

2.2 Front View, Dimensions and Panel Cutout of EGG HATCHER

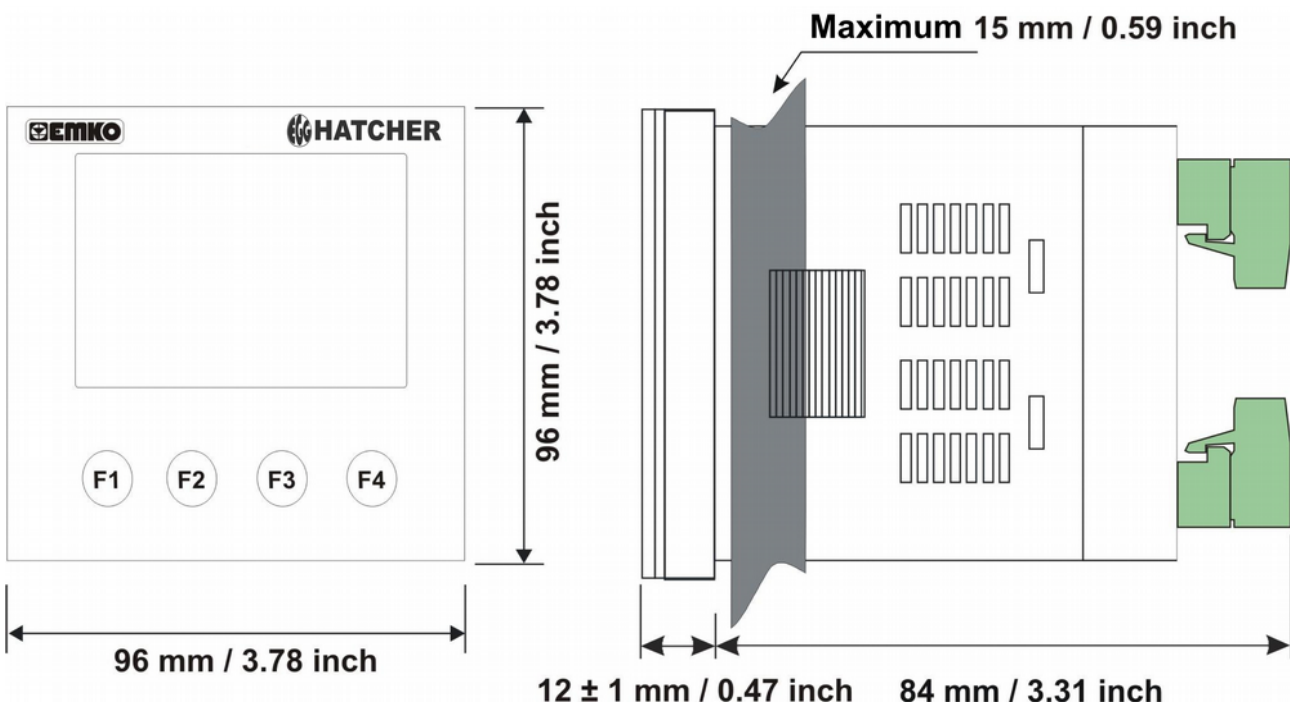

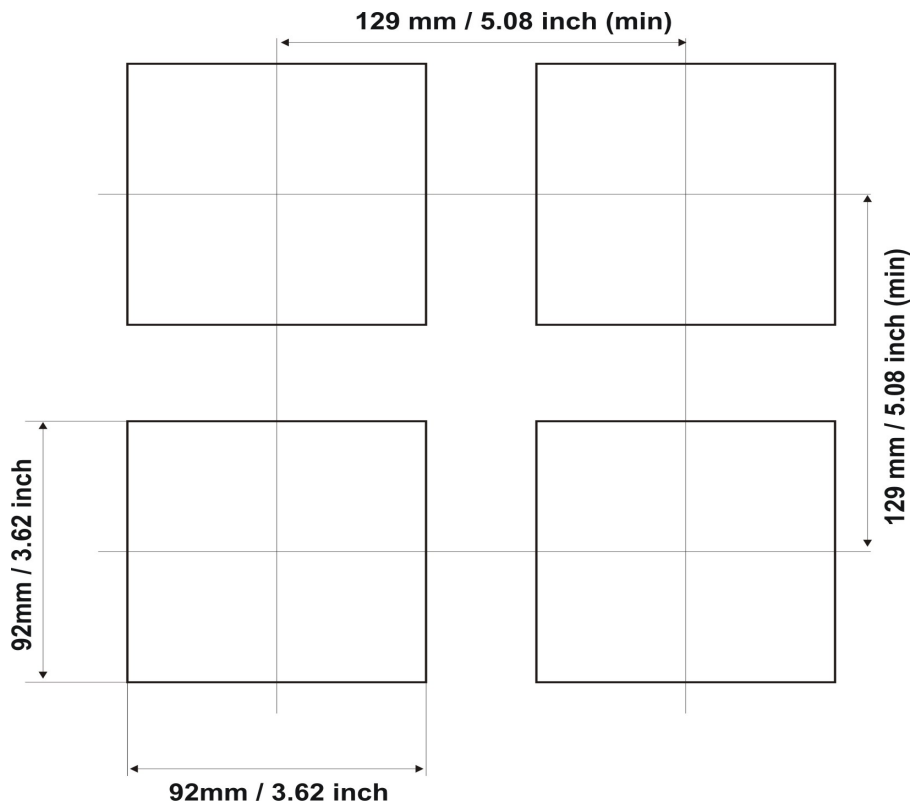

2.3. Panel Mounting



During installation into a metal panel, care should be taken to avoid injury from metal burrs which might be present. The equipment can loosen from vibration and become dislodged if installation parts are not properly tightened. These precautions for the safety of the person who does the panel mounting.

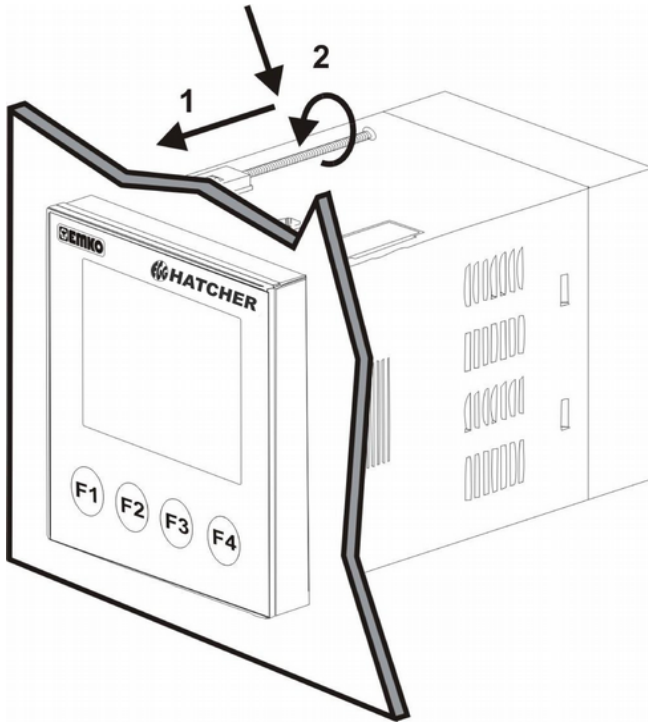

The unit is designed for panel mounting.

1 – Insert the unit in the panel cut-out from the front side.

2 – Insert the mounting clamps to the holes that located top and bottom sides of device and screw up the fixing screws until the unit completely immobile within the panel

2.4 Electrical Wiring Diagram

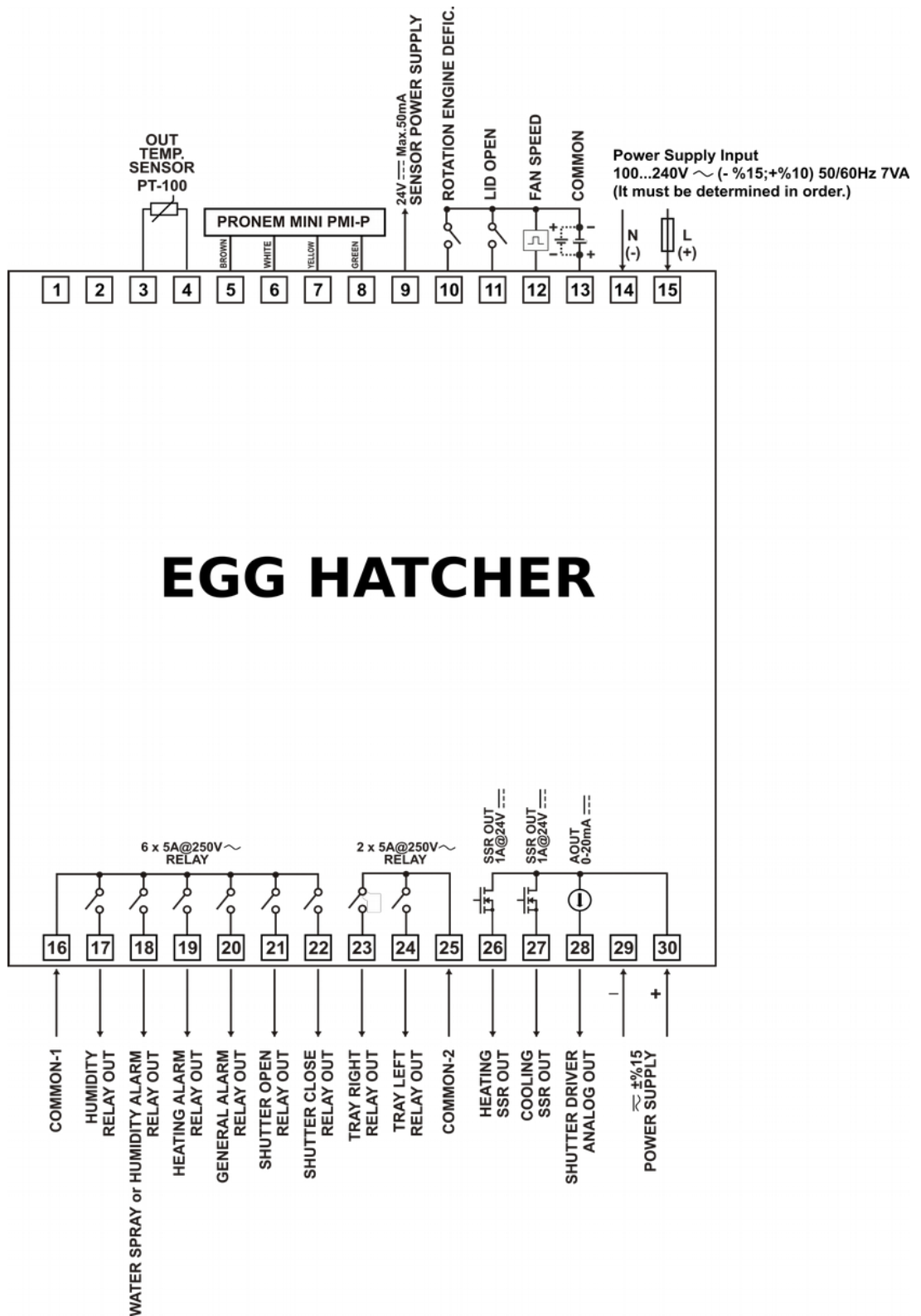

Electrical Wiring Diagram for Pronem Type Input Card

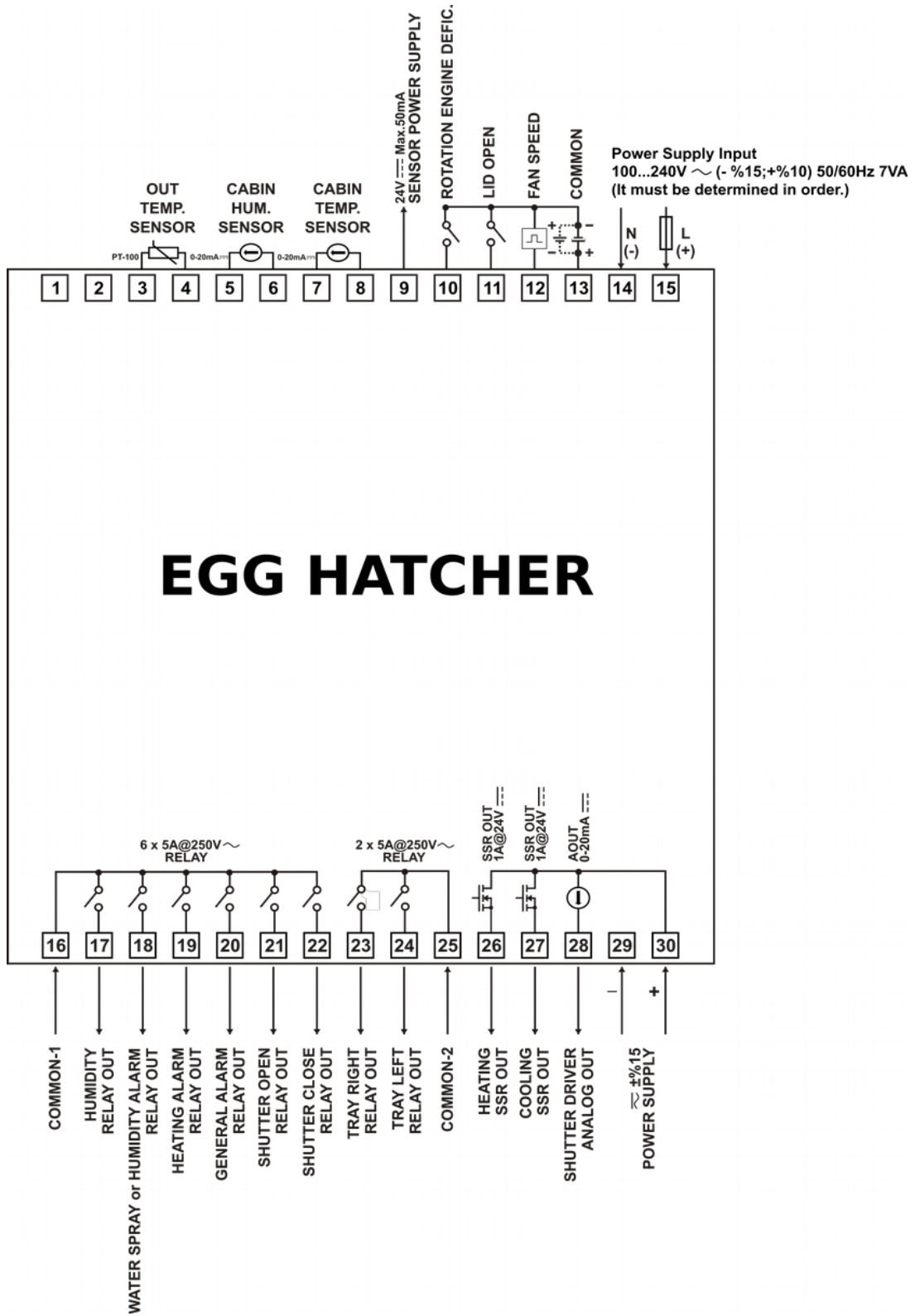

3. MAIN OPERATION SCREEN AND GENERAL DESCRIPTION

3.1. Main Operation Screen

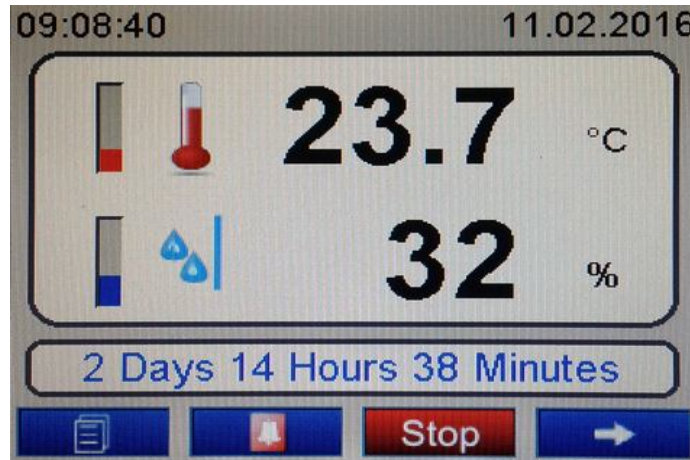

Actual date is located on the top left corner and Actual time is located on the top right corner.



Cabinet Temperature



Cabinet Humidity

Hatching time is showed as a day, hours and minute in label which is bottom of temperature and humidity label. When any alarm is occurs, the alarm definition is showed in this label.



Used to access Menu page



Used to silence the buzzer.



Used to start the hatching time.



Used to stop the hatching time



Used to access second working page

3.2.Second Working Page

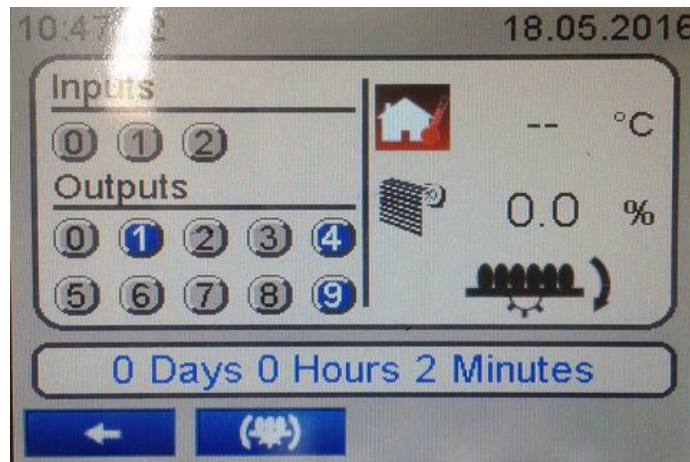

Actual date is located on the top left corner and Actual time is located on the top right corner.



Outer Temperature



Actual Shutter status



Actual Tray rotation direction

Current Inputs and Outputs status are showed on screen.

Inputs:

- 0 – Fan digital Input status
- 1 – Cabinet Door Open Input status
- 2 – Tray Rotation Limit Input status

Outputs:

- 0 – Cooling SSR output status
- 1 – Heating SSR output status
- 2 – Tray Rotation Left Relay output satus
- 3 – Tray Rotation Right Relay output satus
- 4 – Shutter Close Relay output status
- 5 – Shutter Open Relay output status
- 6 – General Alarm Relay output status
- 7 – Temperature Alarm Relay output status
- 8 – Humidifier Alarm/Water Spray Realy output status
- 9 – Humidifier Relay output status

Hatching time is showed as a day, hours and minute in label which is bottom of Input/output status label.



Used to return Main Operation Page



Used to start manual Tray rotation.

3.3. Menus

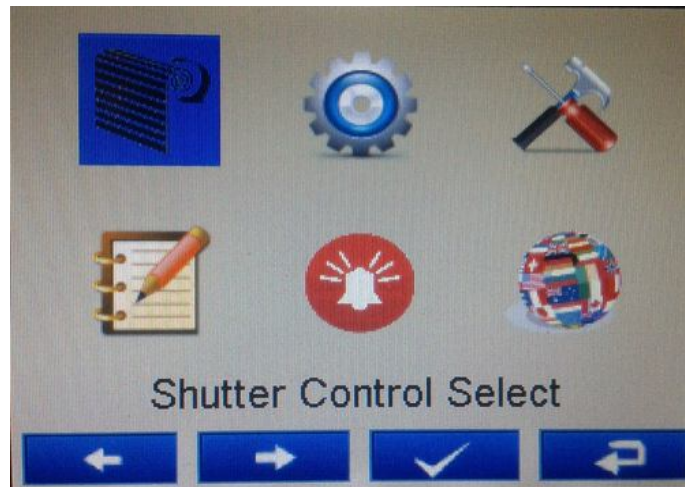

Shutter Control



Settings



Advanced Settings



Logs



Alarms



Language Selection

3.4. Button Definetions

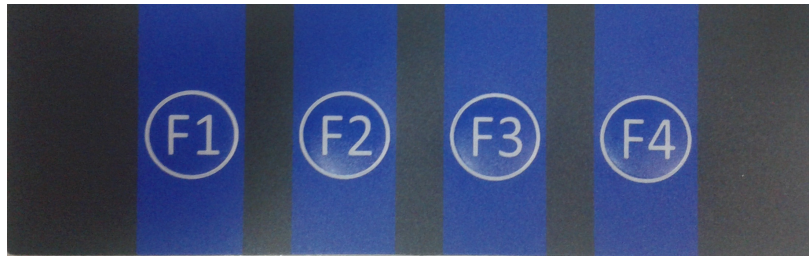

Device has four buttons which are F1, F2, F3 and F4 buttons. These buttons have different functions on different pages.



Up/Down buttons: Used to go up and go down in menus and lists and also used to increase/decrease parameter's value.



Left/Right buttons: Used to go left or right in menus.



Confirm button: Used to go in to selected page, to make parameter's cell available to change and to confirm parameter's change.



Return button: Used to go back to previous menu and to cancel parameter's change.



Alarm button: Used to suspend alarms.



Erase button: Used to erase logs on the screen.

4. MANUAL SHUTTER CONTROL

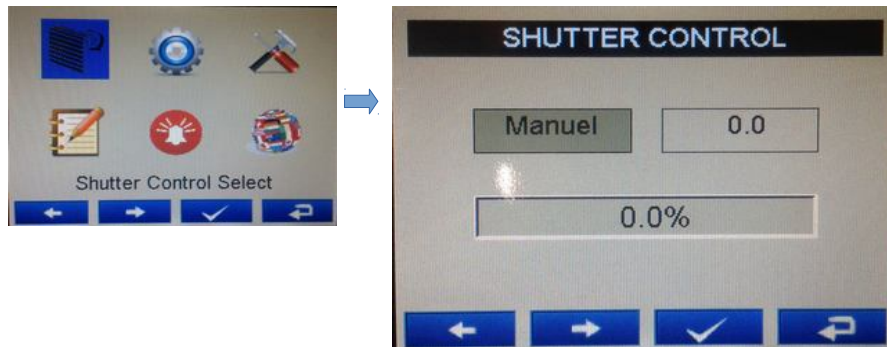

Shutter control manual/automatic selection is can be made in this page.
If shutter control is selection as a manual, shutter status is can be adjusted manually.

5. SETTINGS

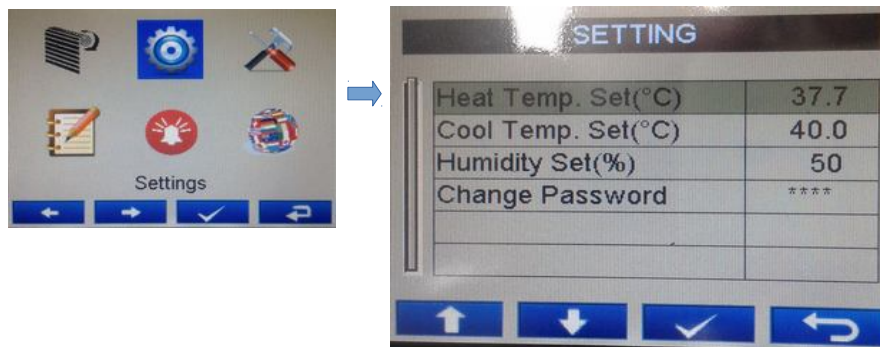

Heat Temperature Set(°C):(Default = 37,7) Set value for heating control output.

Cool Temperature Set(°C):(Default = 40) Set value for cooling control output.

Humidity Set(%):(Default = 50) Desired cabinet humidity value.

Backlight OnLevel(%):(Default = 50) Backlight in normal operation. This parameter is can be adjusted from 50 to 100.

Backlight OffLevel(%):(Default = 20) ECO mode for backlight; in case off selection no backlight . This parameter is can be adjusted from 1 to 100. When this parameter value is 1, if decrement button is pressed, 'OFF' is observed. In this time the screen turns off.

Backlight OffTime(sec):(Default = 20) Time for the access to economic backlight mode. This parameter is can be adjusted from 10 to 300.

Temp. Filter Value:(Default = 100) Temperature filtering coefficient factor. This parameter is can be adjusted from 1 to 300.

Hum. Filter Value:(Default = 1) Humidity filtering coefficient factor. (not activated yet)

Change Password:(Default = 0000) It is used to access to user password changing screen.

6. ADVANCED SETTINGS



These following pages can be accessed via Advanced Settings Menu:

- 6.1 Control Parameters
- 6.2 Device Settings
- 6.3 Calibration

6.1. CONTROL PARAMETERS

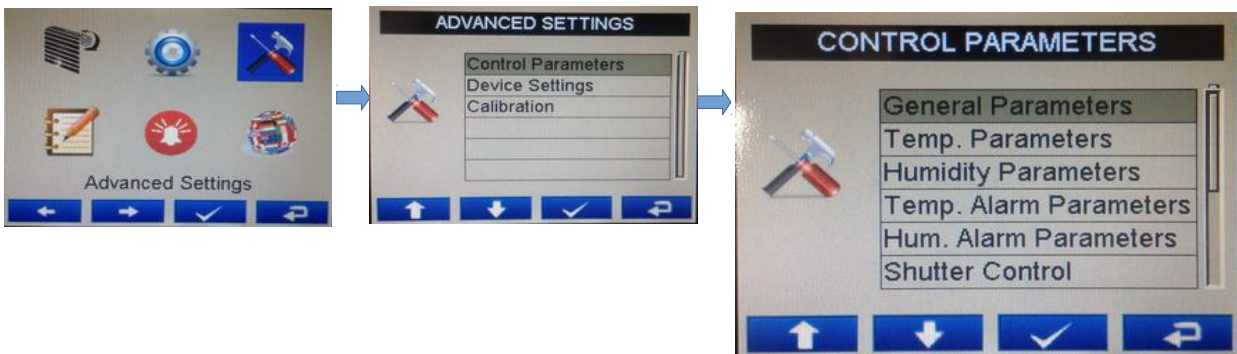

This menu contains parameters pages related to control function of the device.

6.1.1. GENERAL PARAMETERS

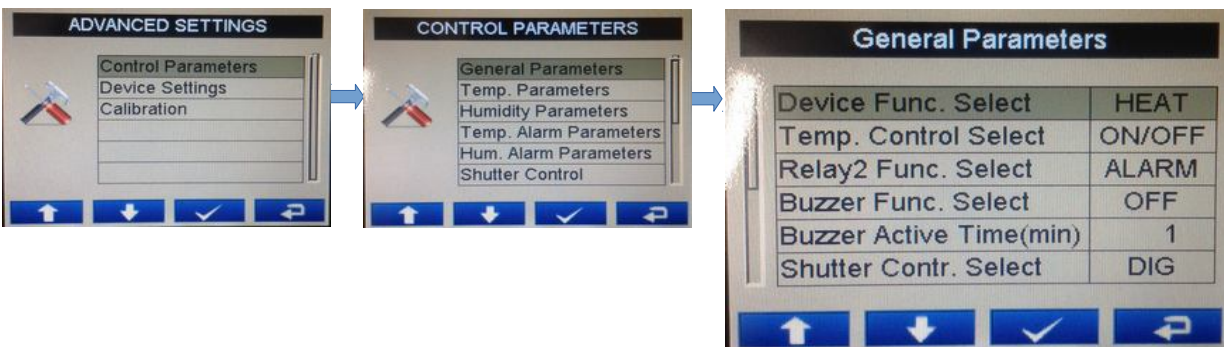

This menu contains parameters related to general operation functions.

Temperature Control Select (Default =ON/OFF): Temperature control 'ON/OFF' or 'PID' selection can be made with this parameter.

Water Spray&Hum Alarm(Default =HUMIDITY ALARM): Relay2 output function selection can be made with this parameter. This parameter must be set ('SU PSK') for Water spray function or ('ALARM') for Humidity Alarm function.

Buzzer Function Select(Default =OFF): Buzzer activation on when alarm occurs is selected with this parameter.

Buzzer Active Time(min)(Default =1): Buzzer active time can be defined with this parameter. It can be adjusted from 1 to 99 minutes. When this parameter is 99, if the increment button is pressed, (---) is observed. In this condition, the buzzer is active until the buzzer silence button is pressed.

Shutter Control Select(Default =DIGITAL): Shutter control output selection can be made with this parameter. This parameter must be set ('ANL') for analog output, or ('DIG') for digital output.

Lid Open Delay(sec)(Default =OFF): If Cabinet door is opened much more time with this parameter value, door open alarm is occur. This parameter is can be adjusted from 0 to 300 seconds. When the parameter value is 300, if increment button is pressed, (OFF) is observed. In this time door open alarm is passive.

Rotation Motor Feedback (Default =OFF): Whether tray motor limit switch using can be made with this parameter. If tray motor limit switch will be use this parameter value must be ON, otherwise parameter value must be OFF.

Fan Speed (rpm)(Default = OFF) Fan Speed alarm value is adjusted with this parameter. When the readed fan speed value is lower than this parameter value Fan Alarm is occur. This parameter value is adjusted from 1 to 30 000 rpm. When this parameter value is 1, if decrement button is pressed, 'OFF' is observed. In this time Fan speed alarm is passive.

OutTemp Offset: (Default = 0) This parameter is can be adjusted from -12.0°C to 12.0°C

6.1.2. TEMPERATURE PARAMETERS

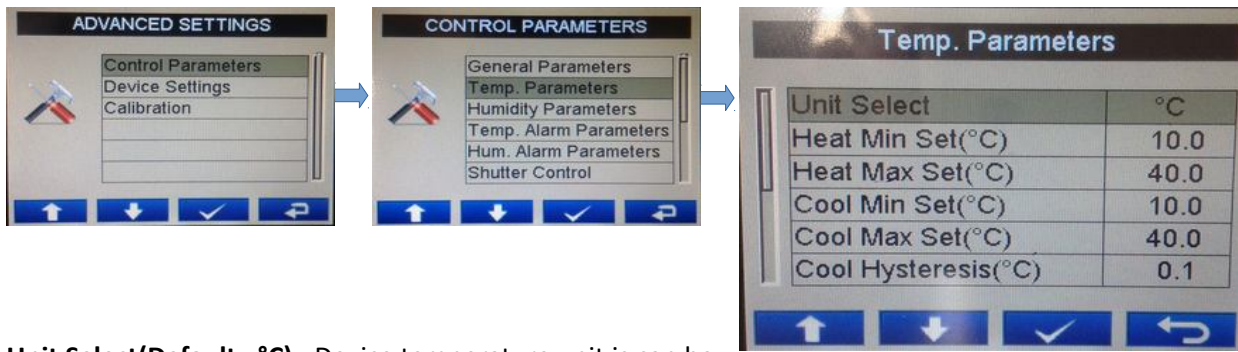

Unit Select(Default =°C): Device temperature unit is can be selected as a '°C' or '°F' with this parameter.

Heat Min. Set (°C):(Default =10) Heating Temperature set value can not be lower than this value. This parameter value can be adjusted from minimum value of device scale to Heating Max. Set parameter value.

Heat Max. Set (°C):(Default =40) Heating Temperature set value can not be higher than this value. This parameter value can be adjusted from Heating Min Set parameter value to maximum value of device scale.

Cool Min. Set (°C):(Default =10) Cooling Temperature set value can not be lower than this value. This parameter value can be adjusted from minimum value of device scale to Cooling Max. Set parameter value.

Cool Max. Set (°C):(Default =40) Cooling Temperature set value can not be higher than this value. This parameter value can be adjusted from Cooling Min Set parameter value to maximum value of device scale.

Sensor Offset(°C):(Default =0) This parameter is can be adjusted from -10.0°C to 10.0°C

Heat Hysteresis:(Default =0.1°C) This parameter is active If heating control selection parameter value is selected as a ON/OFF. This parameter value is can be adjusted

0.1°C to 10.0 °C for Pronem Mini PMI-P (-20.0°C, 80.0°C)

0.1°C to 18.0 °C for Pronem Mini PMI-P (-4.0°C, 176.0°C)

Cool Hysteresis:(Default =0.1°C) This parameter value is can be adjusted

0.1°C to 10.0 °C for Pronem Mini PMI-P (-20.0°C, 80.0°C)

0.1°C to 18.0 °C for Pronem Mini PMI-P (-4.0°C, 176.0°C)

Sens Low Value (Default =-20.0) This parameter is can be adjusted from -200.0°C to 1000.0°C

Sens High Value (Default =80.0) This parameter is can be adjusted from -200.0°C to 1000.0°C

Sensor Scale (Default =Scale1) Scale1: 0-20mA,
Scale2: 4-20mA

The below parameters is can be used If temperature control selection parameter is selected as a 'PID'.

Proportionally (Proportional Control Parameter)(Default =50): This parameter is can be adjusted form 0 to 100 value.

Integral(Integral Parameter)(Default =1000): This parameter is can be adjusted from 0 to 3600 value.

Derivative (Derivative Parameter)(Default =250): This parameter is can be adjusted from 0 to 3600 value.

Period Time (second)(Default =1): This parameter is can be adjusted from 1 to 50 seconds value.

Auto Tune:(Default =OFF): This parameter value must be 'ON' for starting the auto tune function. After auto tune function is finished, automatically this parameter value is return to 'OFF' value.

6.1.3. HUMIDITY PARAMETERS

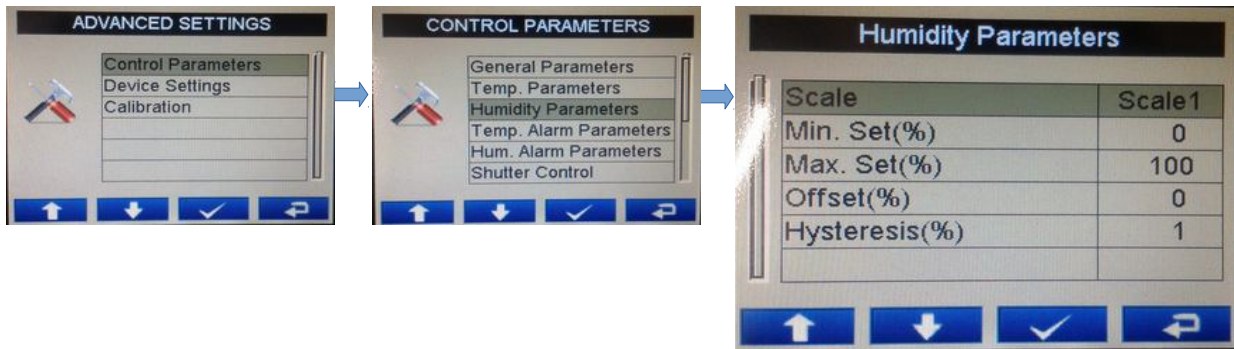

Min. Set (%) (Default =0): Humidity set value can not be lower than this value. This parameter value can be adjusted from minimum value of device scale to Max. Set value parameter

Max. Set (%) (Default =100): Humidity set value can not be greater than this value. This parameter value can be adjusted from Min. Set value parameter to maximum value of the device scale.

Offset(%) (Default =0): Humidity sensor offset value is can be set with this parameter. This parameter is can be adjusted from -10 to 10 %RH.

Hysteresis (%) (Default =1): Hysteresis value can be adjusted wit this parameter. This parameter is can be adjusted from 1 to 10 %RH.

Scale (Default =Scale2) This parameter is active only if analogue inputs type is selected as a universal (EGG HATCHER X/20.X.X.X). Parameter value is can be adjusted as a
Scale1: 0-20mA,
Scale2: 4-20mA

6.1.4. TEMPERATURE ALARM PARAMETERS

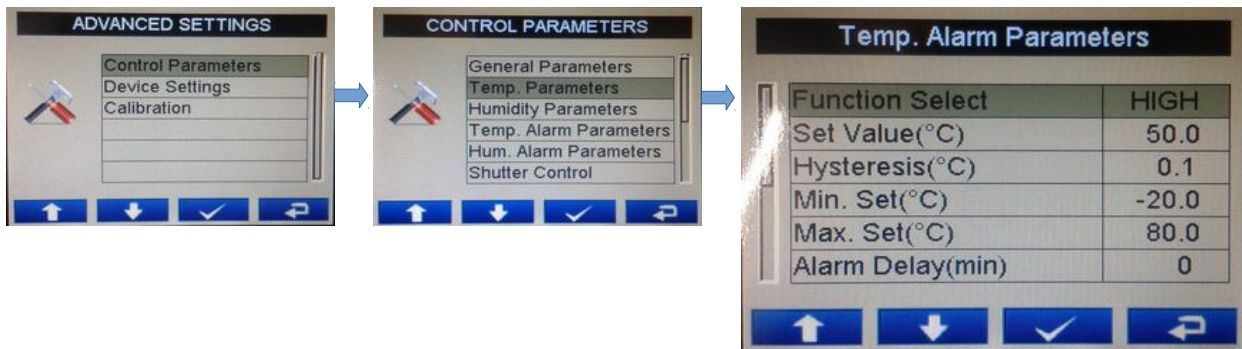

Function Select(Default =High Alarm): Alarm type is selected with this parameter. This parameter can be adjusted as a High Alarm, Low Alarm, Band Alarm or Range Alarm.

Set Value (°C)(Default =50) Alarm set value is adjusted with this parameter. This parameter is can e adjusted between Min temperature alarm set parameter value to Maksimum temperature alarm set parameter value.

Hysteresis(°C)(Default =0.1): Hysteresis value for alarm output is can be adjusted with this parameter. This parameter value can be adjusted from minimum value of device scale to temperature alarm set maximum parameter value.

Min. Set (°C)(Default =-20): Temperature alarm set value can not be lower than this value. This parameter value can be adjusted from minimum value of device scale to Max. Set value parameter

Max. Set (°C)(Default =80): Temperature alarm set value can not be greater than this value. This parameter value can be adjusted from Min. Set value parameter to maximum value of the device scale.

Alarm Delay (minute)(Default =0): Temperature Alarm On Delay Time can be defined with this parameter. It can be adjusted from 0 to 99 minutes.

Starting Alrm Delay(minute)(Default =0): When power is first applied to the device, this time delay must be expired for activation of temperature alarm. It can be adjusted from 0 to 99 minutes.

6.1.5. HUMUDITY ALARM PARAMETERS

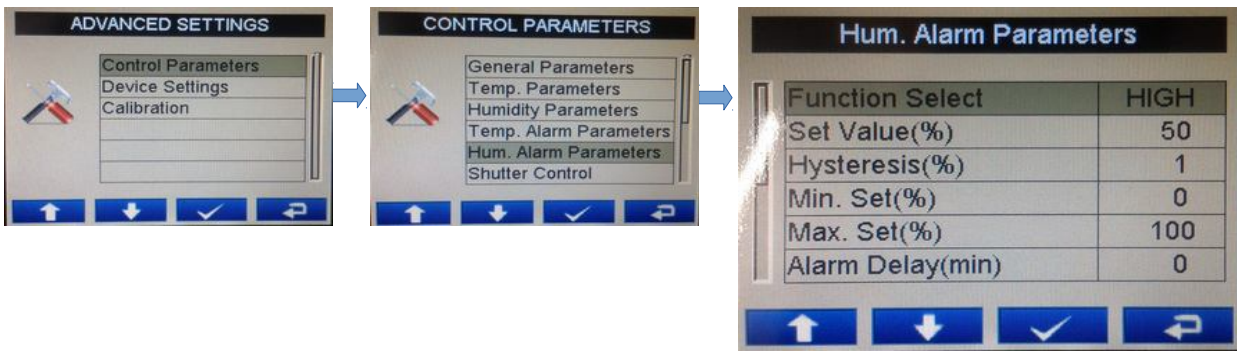

The below parameters is can be used If Relay2 Output function selection parameter is selected as a 'ALARM'

Function Select(Default =High Alarm): Alarm type is selected with this parameter.
This parameter can be adjusted as a High Alarm, Low Alarm, Band Alarm or Range Alarm.

Set Value (°C)(Default =50) Alarm set value is adjusted with this parameter.
This parameter is can e adjusted between Min Humidity alarm set parameter value to Maksimum humidity alarm set parameter value.

Hysteresis(°C)(Default =0.1): Hysteresis value for alarm output is can be adjusted with this parameter.
This parameter value can be adjusted from minimum value of device scale to temperature alarm set maximum parameter value.

Min. Set (°C)(Default =-20): Humidity alarm set value can not be lower than this value. This parameter value can be adjusted from minimum value of device scale to Max. Set value parameter

Max. Set (°C)(Default =80): Humidity alarm set value can not be greater than this value. This parameter value can be adjusted from Min. Set value parameter to maximum value of the device scale.

Alarm Delay (minute)(Default =0): Temperature Alarm On Delay Time can be defined with this parameter. It can be adjusted from 0 to 99 minutes.

Starting Alrm Delay(minute)(Default =0): When power is first applied to the device, this time delay must be expired for activation of temperature alarm. It can be adjusted from 0 to 99 minutes.

6.1.6. WATER SPRAY PARAMETERS

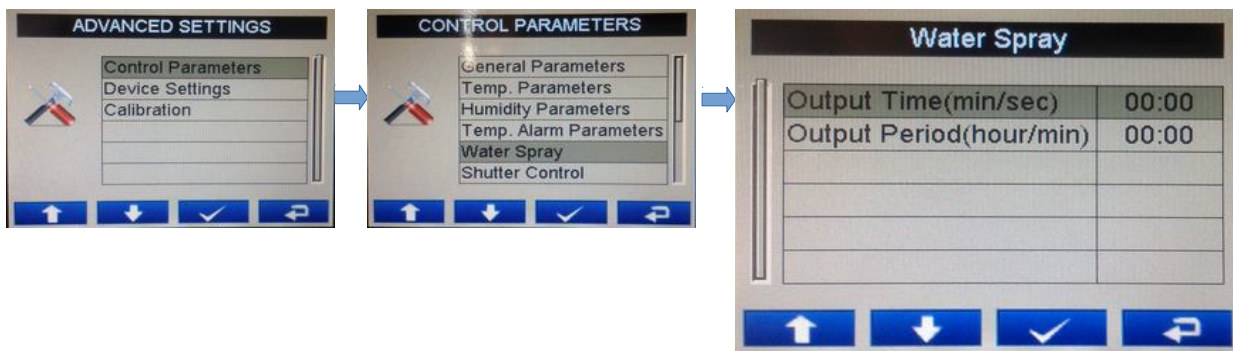

The below parameters is can be used If Relay2 Output function selection parameter is selected as a 'WATER'

Output Time(min/sec)(Default =0): Relay2 output on time value is adjusted wth this parameter.

This parameter value is can be adjusted from 00:00 to 99:00 min/sec.

For changing parameter value first press to ENTER button and minute value is can be adjusted with increment and decrement buttons, after second press to ENTER button second value is can be adjusted with increment and decrement button, after third press to ENTER button parameter value is saved.

Output Period(hour/min)(Default =0): Relay2 Output period time value is adjusted with this parameter.

This parameter value is can be adjusted from 00:00 to 24:00 hr/min.

For changing parameter value first press to ENTER button and hour value is can be adjusted with increment and decrement buttons, after second press to ENTER button minute value is can be adjusted with increment and decrement button, after third press to ENTER button parameter value is saved.

6.1.7. SHUTTER PARAMETERS

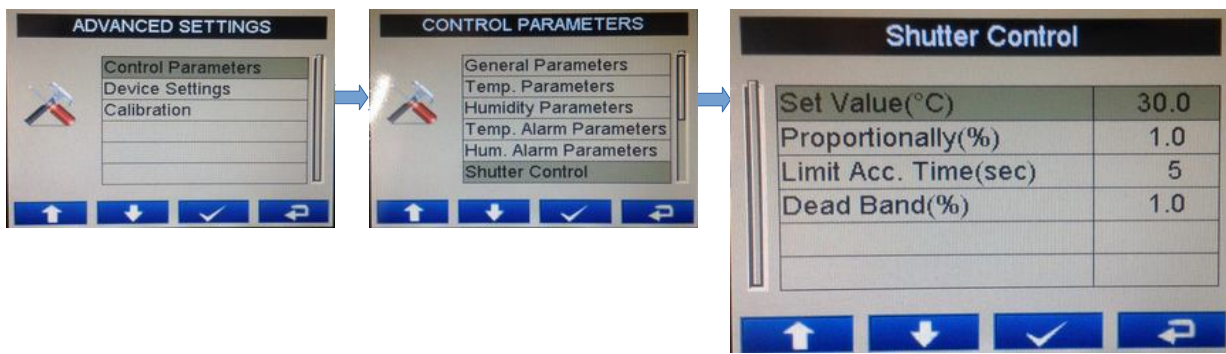

Set Value(°C)(Default =30): Shutter Control set value is adjusted with this parameter.

Proportionally(°C) (Default =1): Proportional value is adjusted with this parameter.

Scale:(Default =Scale1): This parameter is observed if Shutter Control Output Selection parameter is selected as a 'ANL' .

Scale1: 0-20mA/0-10Vdc,

Scale2: 4-20mA/2-10Vdc.

Travel Time(sec)(Default =5): This parameter defines after how many seconds shutter is completely opened. This parameter is can be adjusted from 5 to 600 second.

Step Time(%)(Default =1): Minimum movement steps of shutter while opening or closing are determined as % ratio. This parameter is can be adjusted from 0.1 ile 20.0 %

6.1.8. TRAY ROTATION PARAMETERS

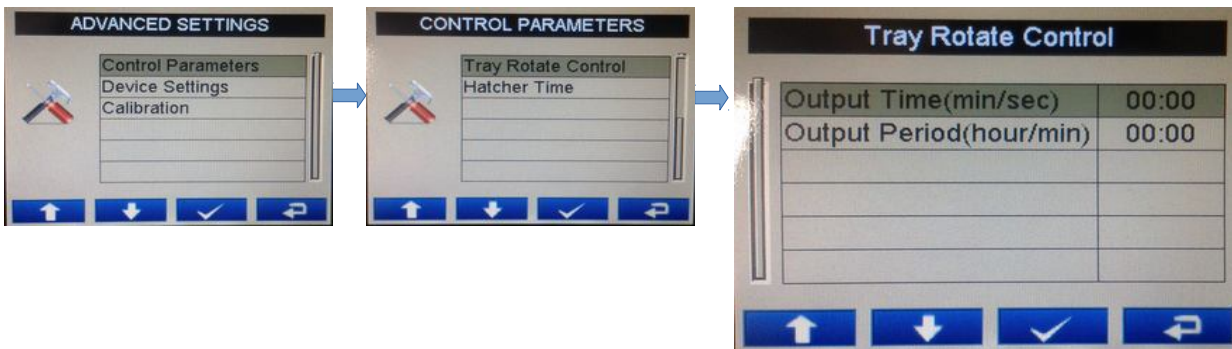

Output Time(min/sec)(Default =0): Tray rotation output on time value is adjusted with this parameter. This parameter value can be adjusted from 00:00 to 99:00 min/sec.

For changing parameter value first press to ENTER button and minute value can be adjusted with increment and decrement buttons, after second press to ENTER button second value can be adjusted with increment and decrement button, after third press to ENTER button parameter value is saved.

Output Period(hour/min)(Default =0): Tray rotation Output period time value is adjusted with this parameter.

This parameter value can be adjusted from 00:00 to 24:00 hr/min.

For changing parameter value first press to ENTER button and hour value can be adjusted with increment and decrement buttons, after second press to ENTER button minute value can be adjusted with increment and decrement button, after third press to ENTER button parameter value is saved.

6.1.9. HATCHING PARAMETERS

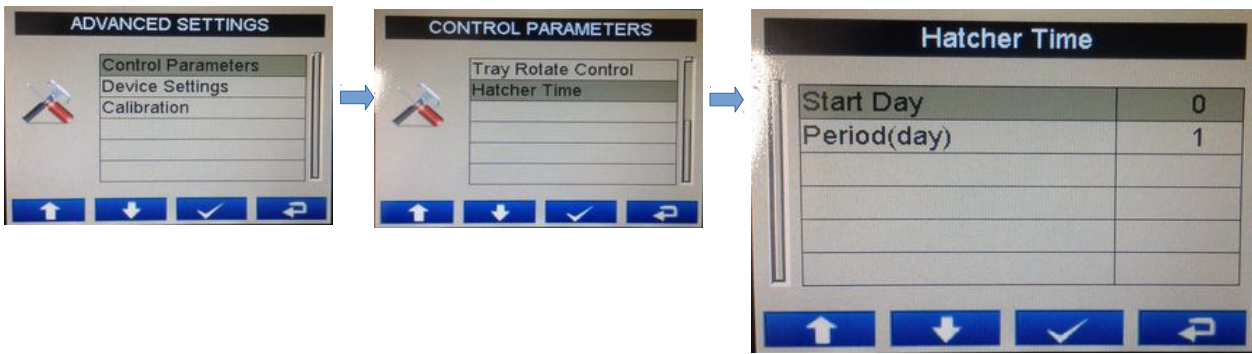

Start Day (Default =0): Hatching Starting Day value is adjusted with this parameter.
This parameter value is can beadjusted from -2 to 0 day.

Period (day)(Default =1): Hatching period time is adjusted via this parameter.
This parameter value is can be adjusted from 0 to 365 day.

6.2 DEVICE SETTINGS

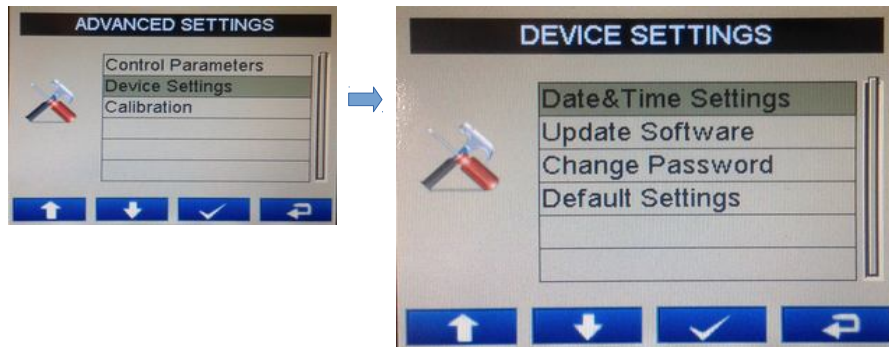

6.2.1 Date & Time Settings

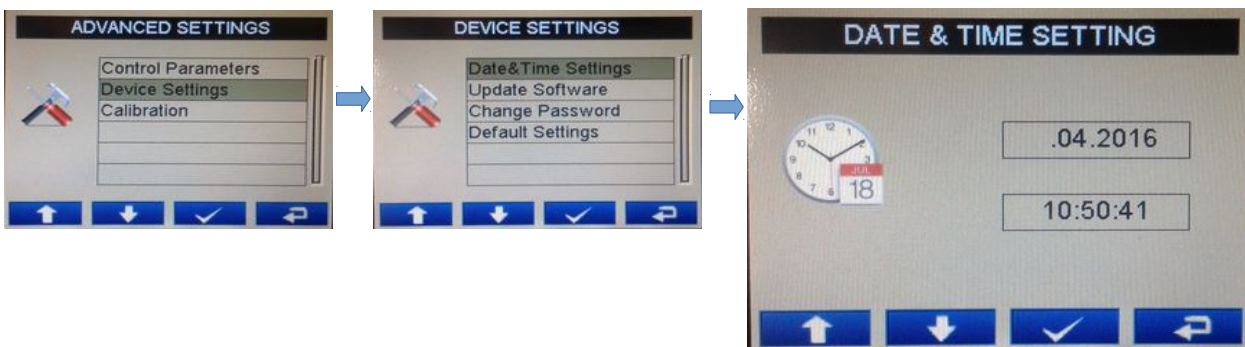

When you return back to previous page, settings are registered.

6.2.2. Update Software

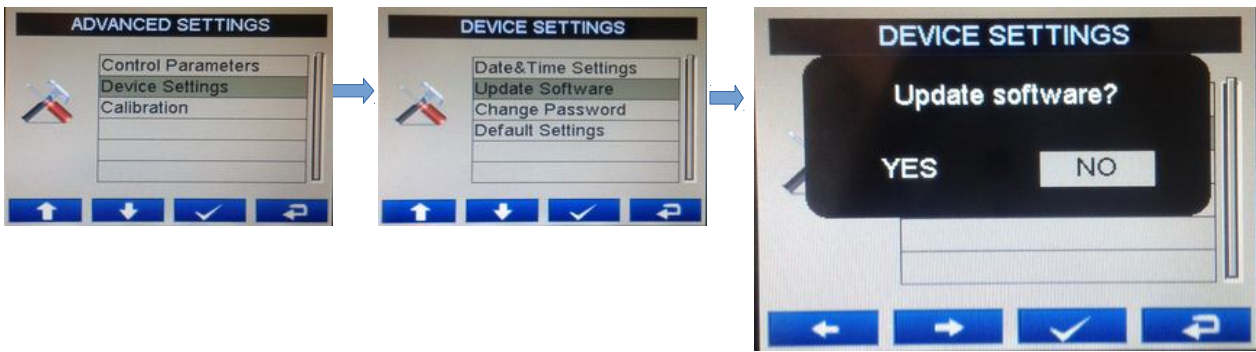

To update HMI software;

1. Insert the flash drive that contains EGGHMI_Vxx.txt file, into the USB port.
2. Restart the HMI device by making power off and on.

To update HMI's bitmaps;

1. Insert the flash drive that contains EGGBMP_Vxx.txt file, into the USB port.
2. Restart the HMI device by making power off and on.

Note: Formatting options of USB disk must be as follow

File System: FAT 32

Allocation Unit Size 4096 bytes

Quick Format: Passive

6.2.3. Default Settings

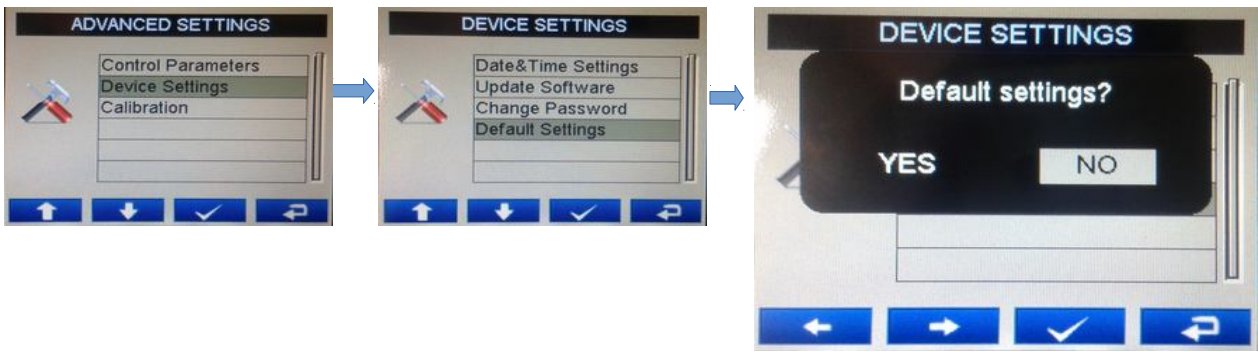

This section is used to return default settings back.

6.2.4. Change Password

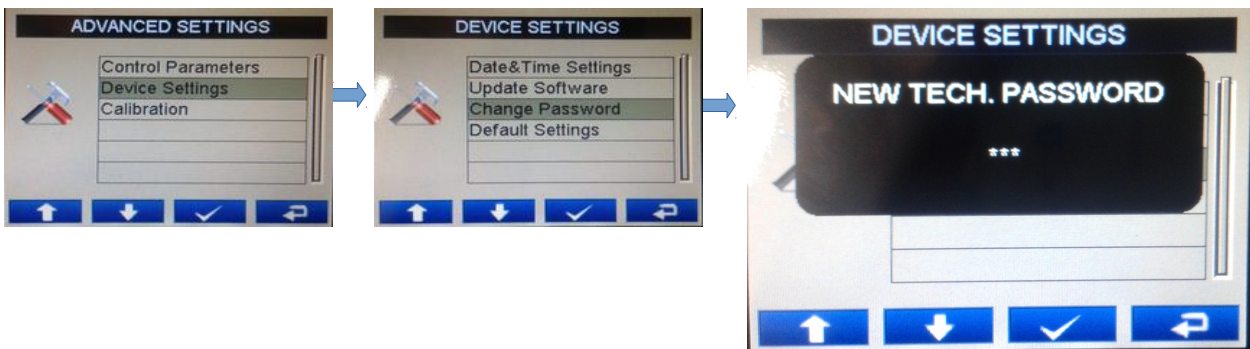

This section is to change Technician Password.

7. LOGS

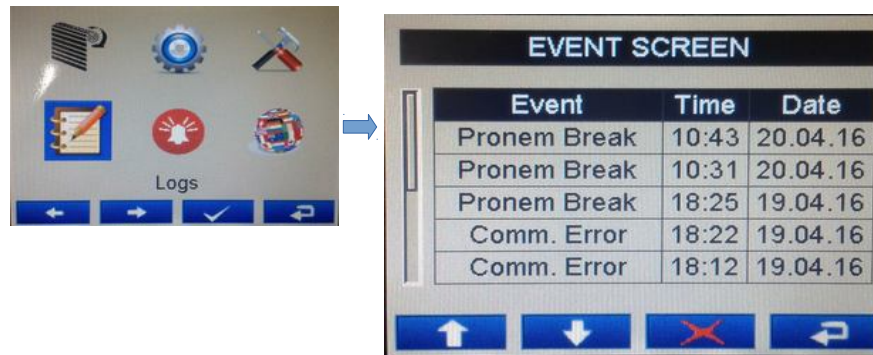

In this page, events logs are shown.

Events occurs when Maximum. values are reached.

- High Temperature
- Low Temperature
- Band Temperature
- Range Temperature
- High Humidity
- Low Humidity
- Band Humidity
- Range Humidity

Events occurs when related digital input becomes active

- Lid Open
- Rotation Motor Fault
- Fan Fault

Events occurs related Process control

- Incubation Period Finish

Events occurs when sensors became broken.

- Pronem Break(for Pronem type input card)

Communication Error:

This event occurs when communication between HMI and main control card has gone down.

8. ALARMS

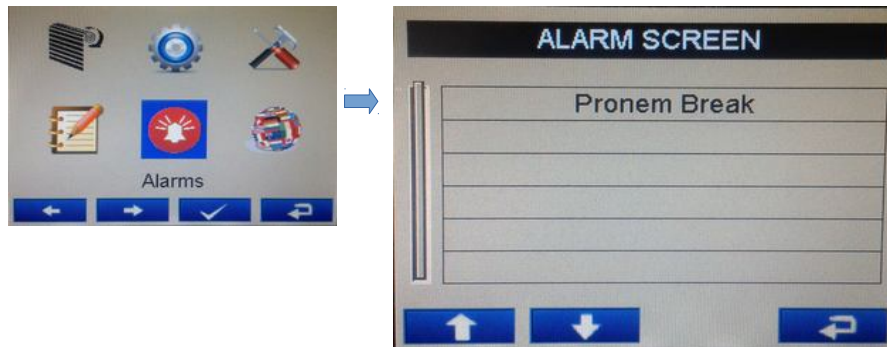

Alarms occurs when Min.Max. values are reached.

- Low Temperature
- High Temperature
- Band Temperature
- Range Temperature
- Low Humidity
- High Humidity
- Band Humidity
- Range Humidity

Alarms occurs when related digital input becomes active

- Lid Open
- Rotation Motor Fault
- Fan Fault

Alarm occurs related Process control

- Incubation Period Finish

Alarm occurs when sensors became broken.

- Pronem Break(for Pronem type input card)

Communication Error:

This alarm occurs when communication between HMI and main control card has gone down.

9. LANGUAGE SELECTION



10. ALARM TYPES

High Alarm

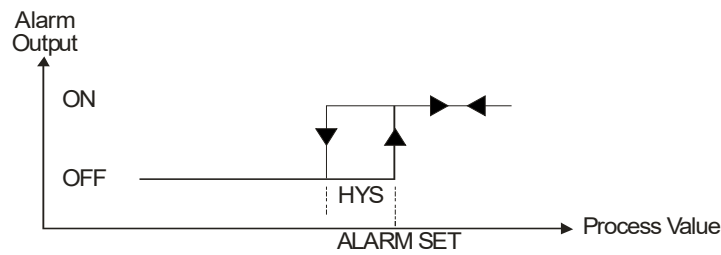

Low Alarm

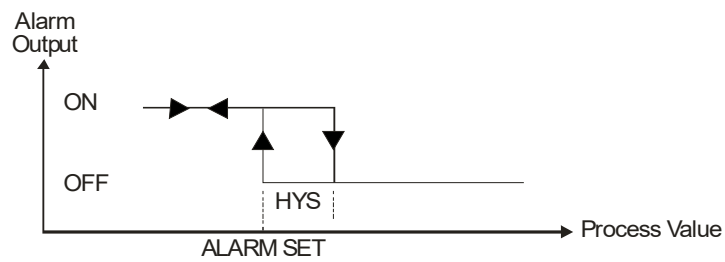

Band Alarm

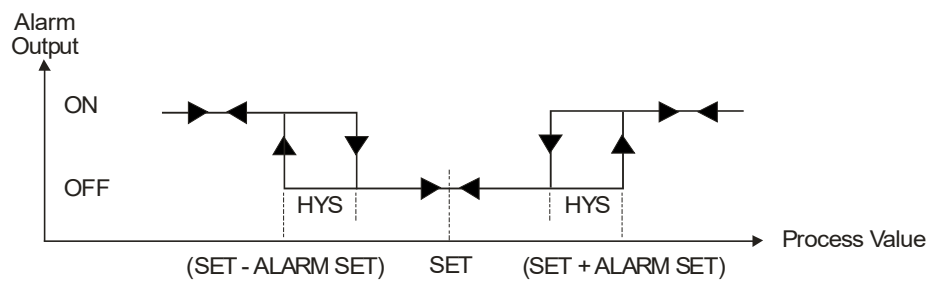

Range Alarm

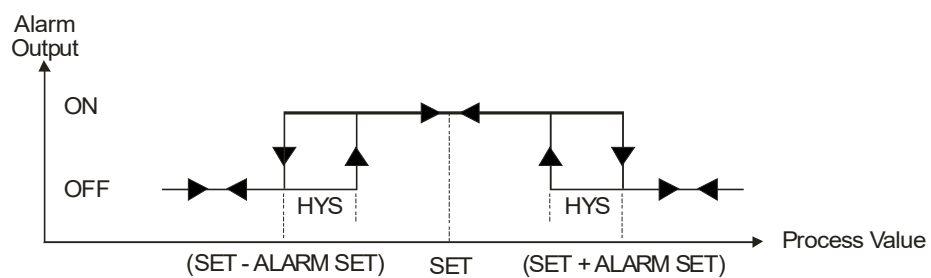

SET = Process Set value
HYS = Hysteresis value for Alarm output

11. SPECIFICATIONS

Device Type : Hatcher Control Device

Housing & Mounting : 96mm x 96mm x 87.5mm 1/4 DIN 43700 plastic housing for panel mounting. Panel cut-out is 92 x 92mm.

Protection Class : IP65 at front, IP20 at rear

Weight : Approximately 0.4Kg.

Environmental Ratings : Standard, indoor at an altitude of less than 2000 meters with none condensing humidity

Storage / Operating Temperature: -20 C to +70°C / 0 C to +50°C

Storage / Operating Humidity : 90 % max. (None condensing)

Installation : Fixed installation

Overvoltage Category : II

Pollution Degree : II. office or workplace, none conductive pollution

Operating Conditions : Continuous

Device Supply Voltage and Power : 100 - 240 V \sim (-%15 / +%10) 50/60 Hz. 7VA

24 V \sim (-%15 / +%10) 50/60 Hz. 7VA

24 V \equiv (-%15 / +%10) 7W

Analogue Sensor Inputs : 0-20mA \equiv , PT-100 (IEC751)(ITS90), PRONEM MINI

Accuracy : \pm % 0,25 of full scale

Sensor Break Protection : Upscale

Max. Pulse Input Value for Fan : 30 000 rpm

Sampling Time : 100 ms

Input Resistance : For 0...20mA \equiv current input 100 Ohm

Digital Inputs : 500 \sim isolated, NPN/PNP selectable

Nominal Input Voltage: 24 V \equiv

Outputs : Relay, 0-20 mA or 0-10 V Analog Output

Analog Output : 0-20mA, 0-10V (maximum 10 mA)

Relay Output : Resistive Load 5A@250V \sim

(Electrical Life : 100.000 operation – Full Load)

SSR Output: PNP(Source) type transistor output (Maximum 1A@24V \equiv)

Display : 320x240 pixel TFT LCD

Approvals : CE, EAC

12. OTHER INFORMATION

Manufacturer Information:

Emko Elektronik Sanayi ve Ticaret A.Ş.

Demirtaş Organize Sanayi Bölgesi Karanfil Sk. No: 6 16369 BURSA/TURKEY

Tel : (224) 261 1900

Fax : (224) 261 1912

Repair and Maintenance Service Information:

Emko Elektronik Sanayi ve Ticaret A.Ş.

Demirtaş Organize Sanayi Bölgesi Karanfil Sk. No: 6 16369 BURSA/TURKEY

Tel : (224) 261 1900

Fax : (224) 261 1912



Thank you very much for your preference to use Emko Elektronik Products.

www.emkoelektronik.com.tr